

## Vertical Balers

### B-series



## Baler B50

### For optimal transport logistics

The B50 baler offers efficient compaction into dense bales with ideal dimensions for optimal transport logistics.

### Perfect pallet size bales

Bales measure 1200 mm x 800 mm x 1100 mm and fit on a standard EUR pallet.

### Highlights

- Machine design and demountable cylinder give a low transport height
- Uses standard 16A outlet
- Short press cycle
- Low noise level
- High compression ratio
- Produces large bales (minimum 400 kg cardboard)
- Powder Coating provides durable finish in many colors.

## Optional Extras



A sliding door stays open by default and gives you hands-free waste filling.



Balers are available in other RAL colours which you may choose.



Gain remote control of your baler with our intelligent fleet monitoring system, BRA-IN.

# Product details

## Baler B50



Whisper

30 dB



Refrigerator

50 dB



B50

62-64 dB



Other balers

75 dB

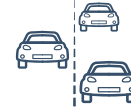

Cars on highway

100 dB



Turbojet engine

160 dB

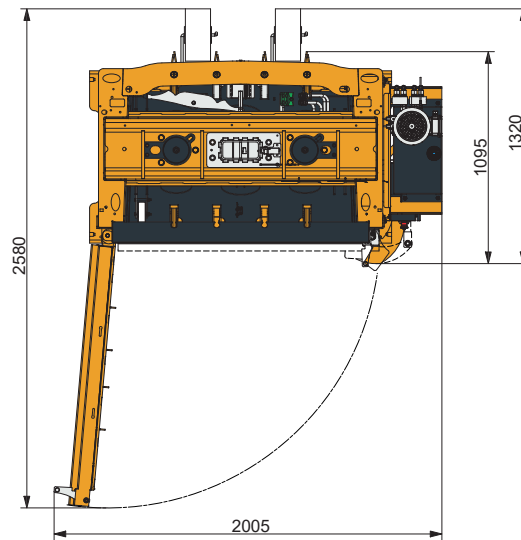
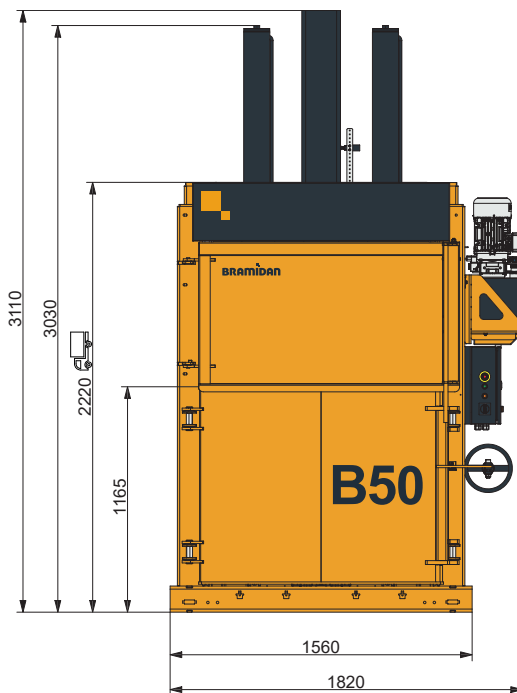

### Technical specifications

Bale size WxDxH (mm)	1200 x 800 x 1100
Feed opening WxH (mm)	1200 x 565
Power supply	3x400V 50Hz 16A
Motor (kW)	5.5
Cycle time avg. (sec)	55 / 26
Dimensions WxDxH (mm)	1820 x 1320 x 3110
Weight (kg)	1800
Stroke (mm)	900
Number of ties	4
Type of tying	Twine / Steel wire
Full bale light	Yes
Bale eject	Automatic



#### Bale weight

Cardboard (kg) 400-500  
Plastic foil (kg) 450-550



#### Press force

50 t



#### Noise level

62-64 dB



#### Waste types

Cardboard, plastic foil, paper.

**BRAMIDAN**  
bramidan.com

Bramidan A/S  
Industrivej 69  
6740 Bramming  
Denmark  
Tel. +45 7517 3266  
bramidan@bramidan.dk